

COMBINATIONAL PROTECTION ALGORITHM EMBEDDED WITH SMART RELAYS

Wagdy M. MANSOUR
wagdy_ibrahim2010@yahoo.com

Mohamed A. ALI
MOHAMED.MOHAMED02@feng.bu.edu.eg

Nader SH. ABDELHAKHEEM
eng_nader2011@yahoo.com

Faculty of Engineering (Shoubra), Benha University, Electrical Engineering Department, 108 Shoubra St., Cairo, Egypt.

Abstract: This paper presents a modern protection algorithm for Out-of-Stability Detection (OOSD) that can be embedded into smart protection relay for real-time power system protection. The presented modern technique employing the Synchronizer Measurement Units (SPMUs) and Extended Energy Function (EEF) proposed in the paper. The proposed EEF reflects the impact of damping into the formulated energy function. The above combinational algorithm provides the Critical Clearing Time (CCT) for transient system disturbances in real-time to provide the adequate tripping signal. Conventional Time Domain Method (CTDM) is used for achieving the instantaneous voltages and currents during all system conditions to be used as inputs for the SPMUs. Then a comparative analysis is made between CTDM and the proposed EEF to prove the validity and effectiveness of the proposed EEF for smart protection.

Keywords: Transient energy function, transient stability analysis, critical energy, CCT, TD, smart protection, smart grids, real-time power system protection, online power system protection.

1. Introduction

Transient stability analysis deals with an actual solution of the nonlinear differential equations describing the dynamics of the machines and their controls and interfacing it with the algebraic equations describing the interconnections through the transmission network [1-3].

The fault may cause structural changes in the network, because of which the power angle curve prior to fault, during the fault and post fault may be different. Stability can be established, for a given fault by solution of the swing equation. The time taken for the fault to be cleared is called the clearing time. If the fault cleared fast enough, the probability of the system remaining stable after the clearance is more. Critical clearing time is the maximum time available for clearing the fault, before the system loses stability.

In the past, transient stability has been evaluated using Time Domain (TD) approach [4, 5], but it's found to be inefficient for evaluating stability for large system. This has encouraged the expansion of various transient stability assessments, such as Equal Area

Criterion (EAC), Extended Equal Area Criterion (EEAC) [6] and Transient Energy Function (TEF) [7, 8], to calculate Critical Clearing Time [9]. Transient Energy Function is known to be a very powerful tool of assessing CCT of a power system without solving the system dynamics equations at post fault. The direct method is capable of providing the information about the degree of stability (or instability). The difficulty in this method is to find the suitable energy function of power system [10]. At the instant of fault occurrence, the electrical power output reduces, accelerates the rotor angle and the system kinetic energy eventually builds up until it arrives at the clearing angle. At this instant, the excess of electrical power output decelerates the rotor angle and the system kinetic energy started decreasing while potential energy started growing up. This indicates that the conversion of system kinetic energy into potential energy is taking place. The successful conversion of accumulated kinetic energy resulted from a particular disturbance in potential energy would result in a constant system's energy towards the end of the transient.

A systematical approach to derive a group of damping reflected energy functions was developed for Single Machine Infinite Bus (SMIB) system by converting some part of damping loss into some appropriate system energy terms [11]. It was shown that the damping-reflected energy function can improve the estimate of stability region, as compared with that by the conventional energy functions which don't consider damping effect.

The synchronized phasors measurement technology is relatively new, and consequently several research groups around the world are actively developing applications of this technology. Synchro-phasor measurements of synchronized voltage and current are used by utilities to control and stabilize the power network. Phasors measurement units use one pulse per milli second signals provided by the Global positioning system (GPS) satellite receivers and a time-stamp device are placed at power plants to obtain power plant variables. The data is then transmitted to a central location where the data can be compared, analyzed and processed. With some local processing power they can be used to determine the generator angles, speeds, accelerations and powers from terminal voltages and currents [12-15]. The accuracy of the GPS is more than enough to ensure that the measurements obtained by such clocks will be simultaneous for the purpose of estimation and analysis of the power system state. The main advantage of PMU is that measured values have same time reference.

The scope of this paper is to produce a modern protection algorithm compatible with smart grids. The algorithm is a combinational nature which consists of several stages. The first stage is the measurement via SPMUs; the second stage is the real-time EEF, while the third stage is the output tripping decision for the relevant circuit breaker.

Single Machine Infinite Bus (SMIB) test system is employed for validate the effectiveness of the proposed modern protection algorithm in real-time.

2. Conventional Transient Energy Function (TEF)

The transient stability detection involves the determination of whether or not synchronism is maintained after the machine has been subjected to severe disturbance. The equilibrium point of a dynamic system $dx/dt = f(x)$ is stable if there exists a continuously differentiable positive definite function

$V(x)$ such that $dV/dt \leq 0$. If the total derivative is negative definite $dV/dt < 0$, then the equilibrium point is said to be asymptotically stable [7].

3. The Proposed Extended Energy Function

The extended energy function algorithm proposed in the paper is based on the classical power system model where generators are represented by constant voltage behind transient reactance. Consider single machine infinite bus system as shown in Fig. 1.

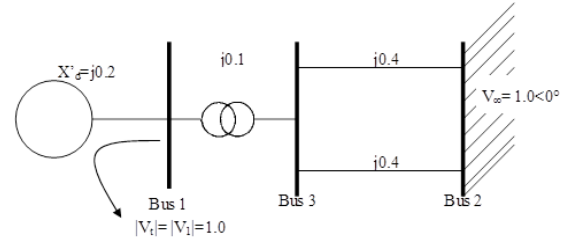

Fig. 1. Single machine connected to infinite bus through two parallel lines.

The swing equation of the above system can be expressed by the well-known differential equations:

$$\frac{d\delta}{dt} = \omega \quad (1)$$

$$M \frac{d\omega}{dt} = \frac{1}{M} (P_m - P_e - Dw) \quad (2)$$

Where M is the generation inertia, P_m is the input mechanical power ($P.u$). P_e is the output electrical power ($P.u$). w is the speed change of the generator rotor and δ is the rotor angle ($deg.$). The output electrical power of a power system is given by:

$$P_e = P_{\max} \sin \delta \quad (3)$$

From eqns. (1), (2) and (3), the Post-fault equation of system given by:

$$M \frac{d\omega}{dt} = P_m - P_{e-postfault} = P_m - P_{\max-postfault} \sin \delta \quad (4)$$

Integrating both sides give the system energy:

$$V(\delta, \omega) = \left[\int_0^{\omega} M\omega d\omega \right] + \left[\int_{\delta_s}^{\delta} [-P_m + P_{\max\text{-postfault}} \sin \delta] d\delta \right] \quad (5)$$

Where subscript (s) denotes another stable equilibrium point in the post fault period. From eqn. (5), the energy function (V) of a power system is given by:

$$V(\delta, \omega) = \frac{1}{2} M\omega^2 - P_m(\delta - \delta_s) - P_{\max\text{-postfault}}(\cos\delta - \cos\delta_s) \quad (6)$$

The time derivative of the energy function V is given by:

$$\frac{dV(\delta, \omega)}{dt} = -D\omega^2 \quad (7)$$

By integrating eqn. (7) in the limit of $[0, t]$ and equating it with eqn. (6), we can derive the following energy function V reflecting the damping effect:

$$V(\delta, \omega) = \frac{1}{2} M\omega^2 - P_m(\delta - \delta_s) - P_{\max\text{-postfault}}(\cos\delta - \cos\delta_s) + \int_0^t D\omega^2 dt \quad (8)$$

In order to estimate the critical clearing time, critical clearing angle and the rotor speed, the differential equations of the fault system with damping are numerically integrated until the instant in which the state trajectory in $w - \delta$ plot leaves the stable region of energy function which doesn't consider damping effect. This implies that the stable region should be extended. Also, this time will be an estimate of the critical clearing time and the total energy of the system is equal to the critical energy. State trajectories for different values of damping are plotted to obtain the relationship between the stable region and the damping constant. It has been shown through the tests that as the damping constant increases, the estimate of stability region also becomes larger.

To reflect the damping effect, it is necessary to change the associated damping term in eqn. (8) into an

appropriate form. This can be done by using the contribution of the curve fitting method for the relationship between the stable region and the damping constant. The damping term can be written as:

$$\int_0^t D\omega^2 dt = K\omega^2 = (A_1 D^4 + A_2 D^3 + A_3 D^2 + A_4 D + A_5) \omega^2 \quad (9)$$

Where A_1, A_2, A_3, A_4 and A_5 constants determined by the curve fitting method. As a result, we can easily obtain a new damping-reflected energy function for SMIB system as follows:

$$V(\delta, \omega) = \frac{1}{2} M\omega^2 - P_m(\delta - \delta_s) - P_{\max\text{-postfault}}(\cos\delta - \cos\delta_s) + K\omega^2 \quad (10)$$

The critical energy is evaluated where $\delta = \delta_u, w = 0$ as indicated in eqn. (11).

$$V_{cr} = -P_m(\delta_u - \delta_s) - P_{\max\text{-postfault}}(\cos\delta_u - \cos\delta_s) \quad (11)$$

Where subscript (u) denotes unstable equilibrium point in the post fault period. With the proposed energy function, transient stability detection is assured if the transient energy at the instant of fault clearing is less than the critical energy.

4. Real-Time Transient Stability Algorithm

The algorithm is a combinational nature which consists of several stages. The first stage is the measurement via SPMUs; the second stage is the real-time EEF, while the third stage is the output tripping decision for the relevant circuit breaker.

The first stage employs the SPMUs to gather the required real-time phasors of voltages and currents to be used for direct calculations for obtaining the correlated values of rotor angle and angular speed. Then the above calculated values will be conveyed to the pre-constructed EEF and plot the maximum energy contour, state trajectory. The smart protection relay (micro-controller based) is used to compare the results. If the state trajectory approaches or into borders the

maximum energy contour, the algorithm provides an output operand states a system disturbance but the system will stay synchronized (Alarm message states normal power swing condition). If the state trajectory outside the maximum energy contours, the algorithm will stop and sends an output operand stating OOS (warning message, the system is OOS). Selectivity algorithm should be adopted to clear the faulted area only by selecting the appropriate circuit breaker to be tripped.

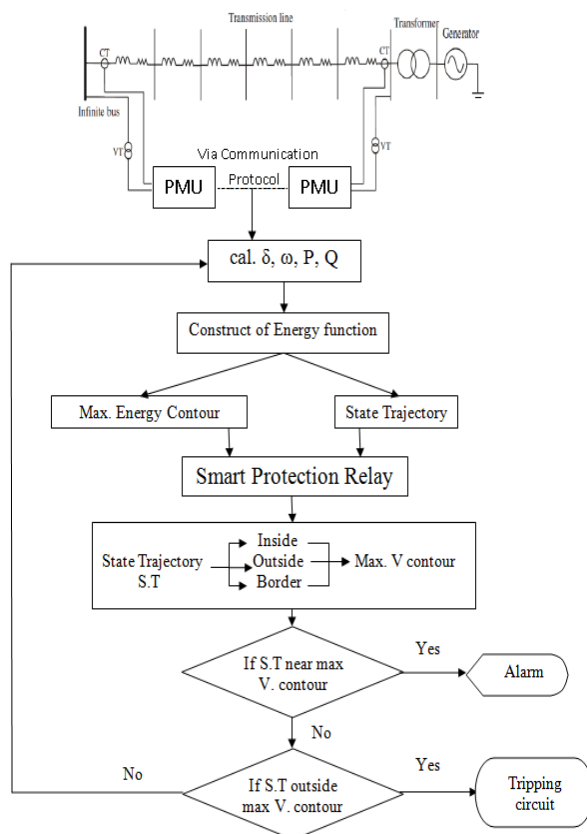

Fig. 2. Smart Protection Algorithm for SMIB.

5. Simulation Results

Simulations have been conducted on SMIB. The CTDM and Transient Energy Function (TEF) have been applied. A three-phase fault occurs on one of the double lines. SMIB system parameters used for simulation are given in Appendix A.

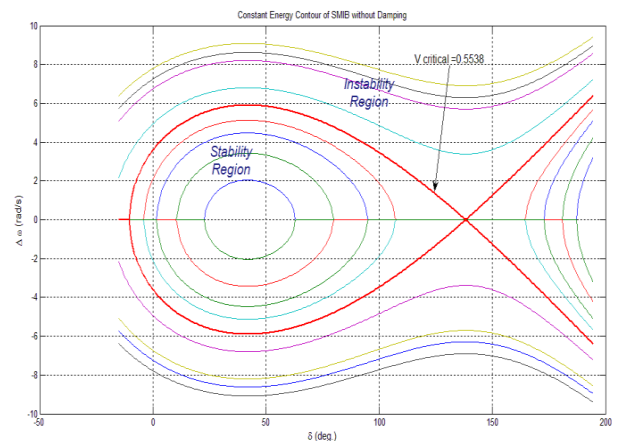

Fig. 3. Max. energy contour of SMIB for sustained fault without damping

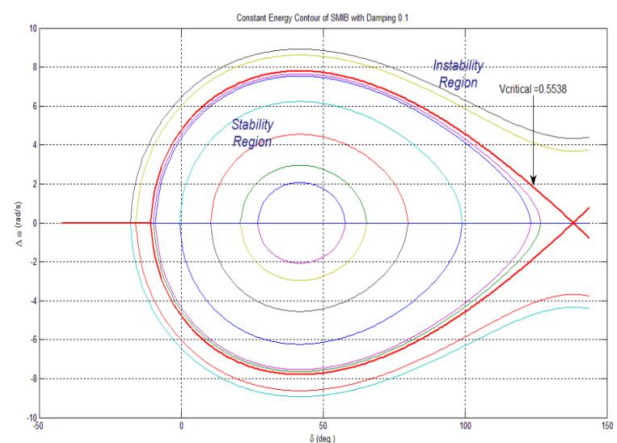

Fig. 4. Max. energy contour of SMIB for sustained fault with damping 0.1

Fig. 3 and 4 show the estimated stability regions without and with damping effect respectively. The CTDM is applied for numerical integration for sustained fault, each time step, the constant V-contour is plotted in ω - δ plot to determine the stability region at maximum V-contour when $V(\delta_c, \omega_c) = V_{cr}$. The closed region inside of the maximum V-contour defines a region of stability. Fig. 4 indicates that the estimated stability region obtained by damping-reflected energy function is larger than that without damping-reflected energy function.

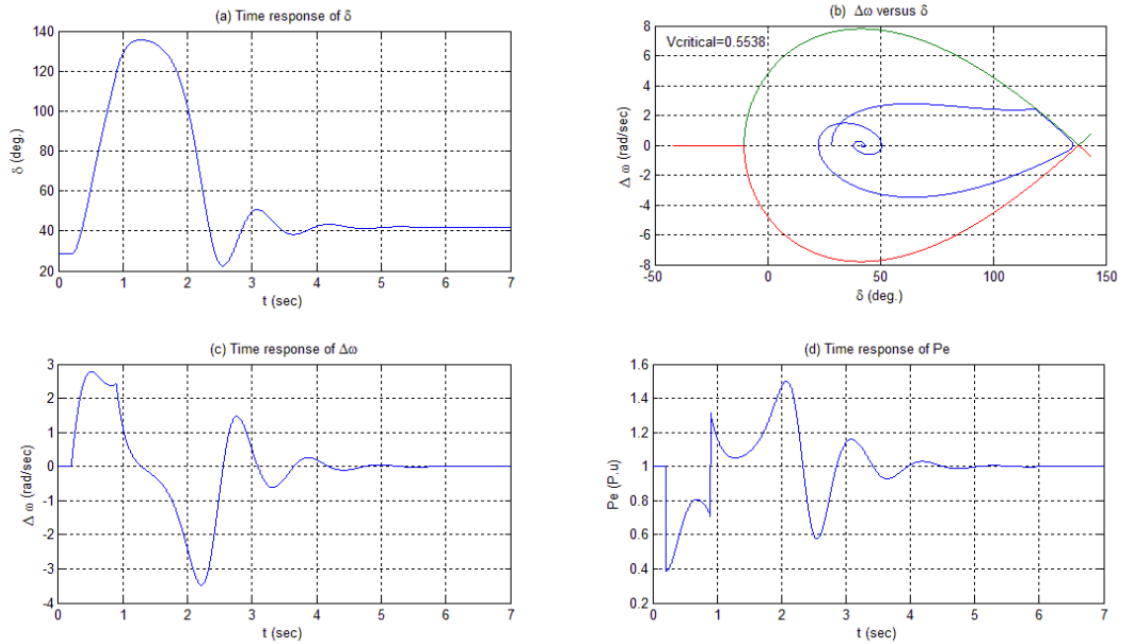

Fig. 5. Time response with fault cleared at $t_c < t_{cc}$, $t_c = 0.7$ sec of δ , $\Delta\omega$, P_e and $\Delta\omega$ versus δ .

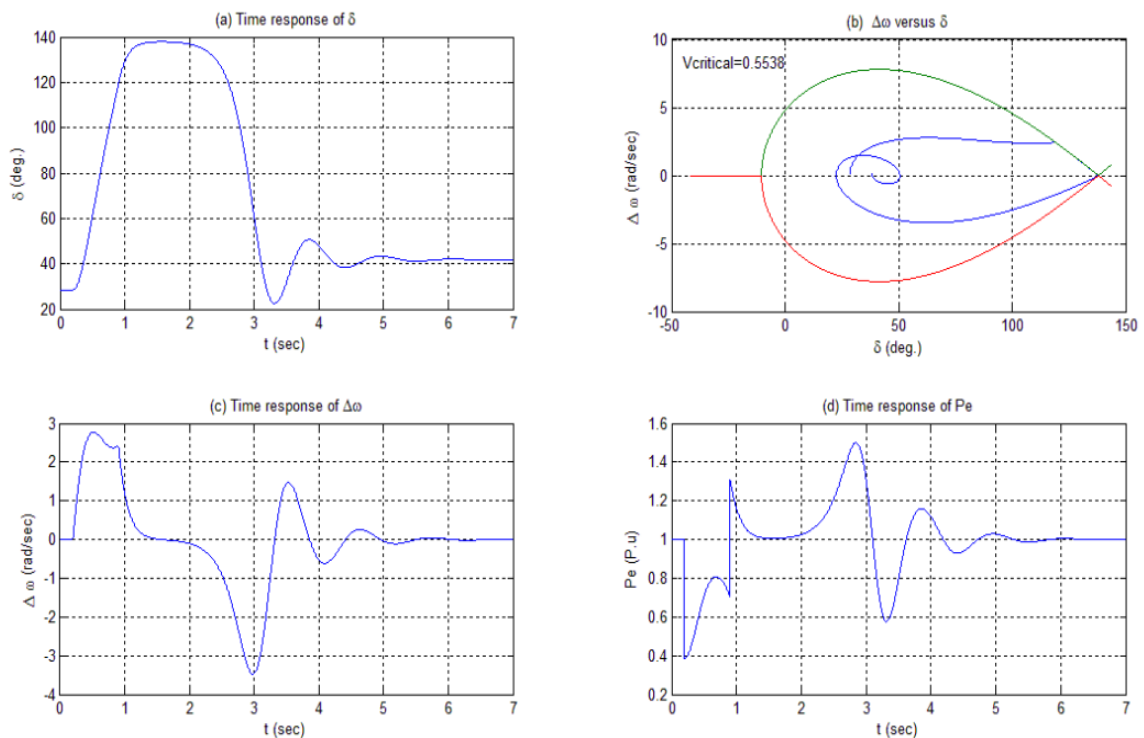

Fig. 6. Time response with fault cleared at $t_c = t_{cc} = 0.70335$ sec of δ , $\Delta\omega$, P_e and $\Delta\omega$ versus δ .

Single machine swing curve and the phase trajectory in $\Delta w - \delta$ plot under post-fault condition are plotted at clearing times of 0.7 sec, 0.70335 sec and 0.71 sec as shown in Fig. 5, 6 and 7. Fig. 5 shows a stable case where the rotor angle oscillates with damping, and reach another stable equilibrium point towards the end of the transient and stability could be assured if the transient energy at clearing condition δ_{cl} and w_{cl} remains in the stable region or $V(\delta_{cl}, w_{cl}) < V_{cr}$. The system is critically stable with fault cleared at 0.70335 sec, corresponding to a critical clearing angle δ_{cr} of 119.4 degrees and critical energy V_{cr} for the

system investigated is 0.5538, which is shown to be the maximum trajectory as shown in Fig. 6. When the fault is cleared at 0.71 sec, system instability resulted and $V(\delta_{cl}, w_{cl}) > V_{cr}$ as indicated in Fig. 6.

The critical clearing time t_{cc} can also be obtained from the P_e versus time curve. That mean when P_e touch P_m in the first swing, then t_{cc} is obtained. Fig. 5 (d) where $t_c < t_{cc}$, P_e is higher than P_m in the first swing. Fig. 6 (d) where $t_c = t_{cc}$, P_e touch P_m . When $t_c > t_{cc}$, the system will be unstable as shown in Fig. 7 (d).

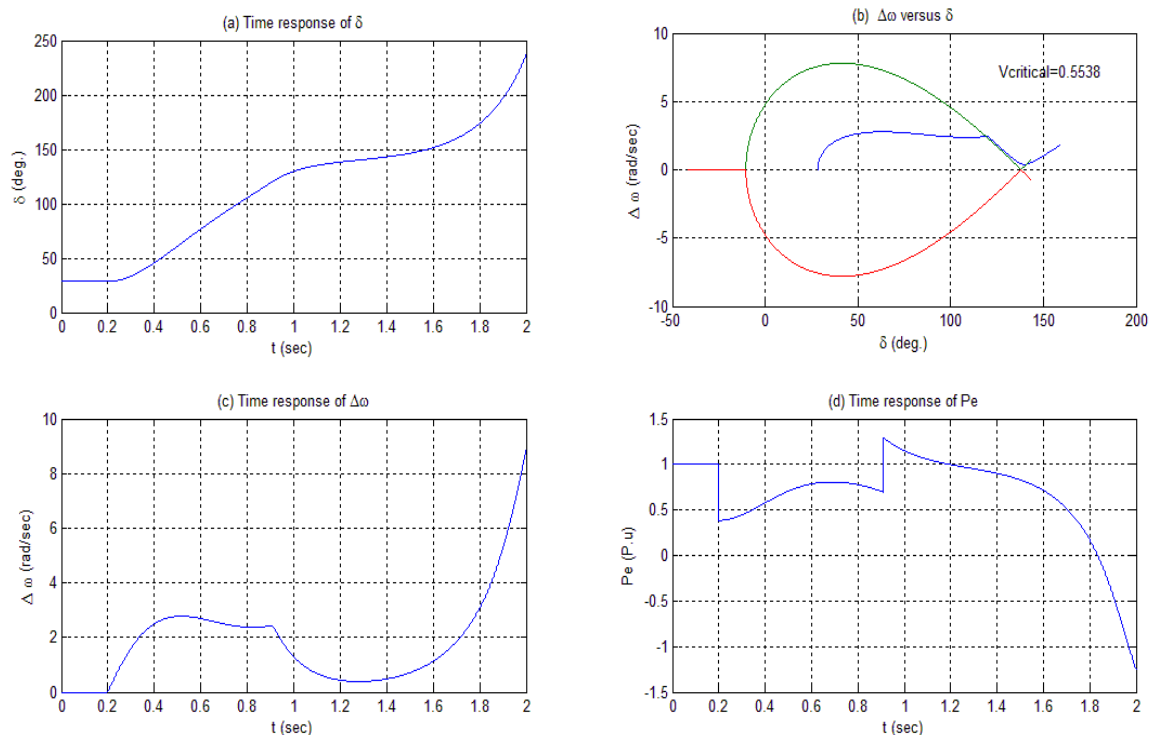

Fig. 7. Time response with fault cleared at $t_c > t_{cc}$, $t_c = 0.71$ sec of δ , Δw , P_e and Δw versus δ .

6. Conclusions

This paper presents a modern protection algorithm for Out-of-Stability Detection (OOSD) that can be embedded into smart protection relay for real-time power generator and distance protection. The presented modern technique employing the Syncro-phasor Measurement Units (SPMUs) and Extended Energy Function (EEF). The proposed EEF reflects the impact

of damping into the formulated energy function. The above combinational algorithm provides the Critical Clearing Time (CCT) for transient system disturbances in real-time to provide the adequate tripping signal. The proposed smart algorithm could be extended for multi-machine power systems via the transient stability Parallel Algorithms in [12, 15].

References

1. Kundur, P., Power System Stability and Control, McGraw-Hill, New York, 1994.
2. P. Kundur, J. Paserba, V. Ajjarapu, G. Andersson, A. Bose, C. Canizares, N. Hatziargyriou, D. Hill, A. Stankovic, C. Taylor, T. Van Cutsem, and V. Vittal, "Definition and classification of power system stability IEEE/CIGRE joint task force on stability terms and definitions", IEEE Transactions on Power Systems, Vol. 19, No. 3, Aug. 2004, pp. 1387 – 1401.
3. M. Pavella and P.G. Murthy, Transient Stability of Power System: Theory and Practice, New York: John Wiley & Sons, Inc., 1994.
4. P. M. Anderson, A. A. Fouad, Power System Control and Stability, John Wiley & Sons, Inc., 2003.
5. D. J. Higham, "An algorithmic introduction to numerical solution of stochastic differential equations", SIAM Rev., Vol. 43, No. 3, pp.525–546, 2001
6. A. Y. Abdelaziz, Amr M. Ibrahim, Zeinab G. Hasan: "Transient stability analysis with equal-area criterion for out of step detection using phasor measurement units" I JEST, Vol. 5, No. 1, 2013, pp.1-17.
7. M. K. Khedkar, G. M. Dhole, V. G. Neve, "Transient Stability Analysis by Transient Energy Function Method: Closest and Controlling Unstable Equilibrium Point Approach," IE (I) Journal – EL, Vol 85, pp. 83-88, September 2004.
8. W. Zhang, H. Zhang, and B.-S. Chen, "Generalized Lyapunov equation approach to state-dependent stochastic stabilization/detectability criterion", IEEE Trans. Autom. Control, Vol. 53, No. 7, pp. 1630–1642, Aug. 2008.
9. Samita Padhi, Bishnu Prasad Mishra: "Numerical Method Based Single Machine Analysis for Transient Stability" IJETAE, Vol. 4, February 2014.
10. L. F. Alberto, F. H. J. R. Silva, and N. G. Bretas, "Extended Lyapunov functions for detailed power system models," In Proc. Of 14th PSCC, 2002.
11. Y.-H. Moon, B.-K. Choi, T.-H. Roh, "Estimating the domain of attraction for power systems via a group of damping-reflected energy functions", Automatica, vol. 36, pp. 419-425, March 2000.
12. Mohamed A. Ali, Wael R. Anis, Wagdy M. Mansour, Fahmy M. Bendary "Novel Real-Time Stability Assessment Algorithm Based On Synchro-Phasors Measurement And Parallel Algorithms For Multi-machine Networks", International Journal of Emerging Electric Power Systems (IJEPS) 2012, Volume 13, issue 3, article 7.
13. Mohamed A. Ali, Fahmy M. Bendary "Design of prototype non directional overcurrent relay micro-controller-based" Electricity Distribution (CIRED 2013), 22nd International Conference and Exhibition DOI: 10.1049/cp.2013.0543, 2013, Page(s):1–4, IET Conference Publications, IEEEXplore.
14. Mohamed A. Ali, Wael R. Anis, Wagdy M. Mansour, Fahmy M. Bendary "ANFIS Based Synchro-Phasors Measurements For Real-Time Estimation of Critical Clearing Time", Fourteenth International Middle East Power Systems Conference (MEPCON'10), Cairo, Egypt, pp. 422:427.
15. Mohamed A. Ali, Wagdy M. Mansour, "Real-Time Transient Stability Analysis/Assessment Based Proposed Parallel Algorithms", International Journal of Electrical and Power Engineering, 2012, Volume: 6, Issue: 4, Page(s) : 124-131, DOI : 10.3923/ijepe.2012.124.131.

Appendix A

System parameters for SMIB

$$\begin{aligned}
 H &= 5MJ/MVA & X'_d &= 0.2\Omega \\
 P_m &= 1P.u & X_{Trans.} &= 0.1\Omega \\
 V_t &= 1P.u & X_{Line1} &= 0.4\Omega \\
 V_\infty &= 1P.u & X_{Line2} &= 0.4\Omega
 \end{aligned}$$